

Directional Coupler Basics

Over the years many different techniques have been utilized to bring about the physical realization of directional couplers. The scope of this article is limited to discussion of quarter-wavelength, coaxial, directional couplers, as this type of coupler represents a balanced compromise between functional range, performance and cost for most broadband applications covering up to an octave bandwidth.

The basic directional coupler is a four port junction that is used in a wide variety of microwave systems to satisfy almost any requirement for sampling incident and reflected microwave power conveniently and accurately with minimal disturbance to the transmission line.

The basic configuration of a single directional coupler is shown in **figure 1** which illustrates two parallel transmission lines over a length of one-quarter wavelength, corresponding with the center frequency of operation. The main and secondary lines are separated by a calculated physical distance which determines the coupling factor of the device. The physically closer the lines are to each other, the more power will be introduced on the secondary line. The term **coupling** denotes how much of the input power is sampled to the coupled port and is defined as 10 times ratio of Incident Power and Forward Power **$C = 10 \log_{10}(P_f/P_i)$** .

Typical coupling values found in practice are 3, 6, 10, 20, 30, 40 & 50 dB; however, practically any coupling value may be obtained through proper design.

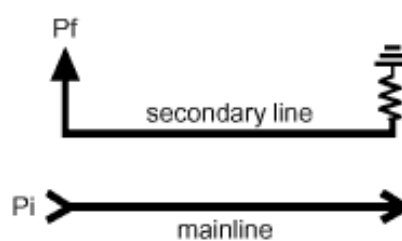

P_i = Incident Power
 P_f = Forward Power

Single Directional Coupler
 Fig. 1

Directional Coupler Theory and Definitions

A dual directional coupler (**figure 2**) is essentially two single directional couplers connected back-to-back sharing a common mainline and providing two output ports with high isolation between those ports. This high isolation is critical for the accuracy of reflectometer set-ups that simultaneously sample input power to a device or load providing a ratio of signals for the purpose of determining return loss in decibels.

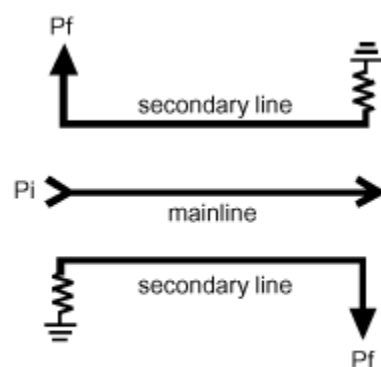

Dual Directional Coupler
 Fig. 2

Source: www.e-meca.com

Directional Coupler Basics (cont.)

When power is introduced at the input port, all of the power appears at the output port except for the portion intended to be sampled. If power is reflected back from the output port, the ideal directional coupler does not allow any of the reflected power to appear on the secondary line. Regrettably, the ideal directional coupler does not exist in our world. Consequently, a small amount of backward power will be coupled to the secondary line 180° out of phase from the incident wave cancelling power on the secondary line and adding uncertainty to the measurement. The term **directivity** (figure 3) denotes the ratio of forward to backward coupling and is defined as 10 times the common log of the ratio of forward and backward power $D = 10 \log_{10}(P_f/P_b)$. The higher the value of directivity, the less backward power is sampled and measurement uncertainty is significantly improved. Directivity is the qualitative benchmark by which couplers are compared.

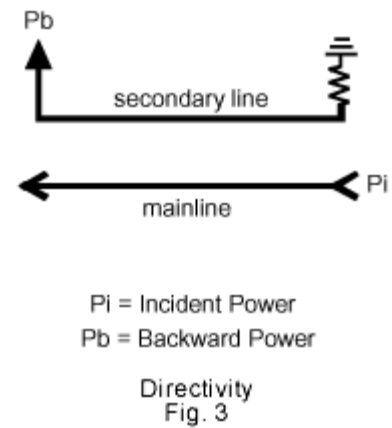

Since we are on the subject of measurement errors, we should also deal with the importance of Voltage Standing Wave Ratio (VSWR) because reflections will add and subtract to the incident signal causing uncertainty in the coupling factor. VSWR is defined as the ratio of incident to reflected signals and is ideally 1.00:1, meaning these signals are in phase and will not cancel. The better the **VSWR**, the less return loss is encountered. Unsatisfactory coupler VSWR will degrade measurement accuracy and is usually attributable to lesser quality connectors or inadequate design techniques.

The **frequency sensitivity** or “flatness” of a coupler is a measure of how coupling varies over a given frequency range. Optimum coupling frequency response is achieved by “centering” the design within the specified band of interest. Typical coupling flatness for a quarter-wavelength coupler operating over an octave band is within ± 0.75 dB of nominal. All things being equal, stronger coupling factors (3, 6 & 10 dB) exhibit greater flatness than weaker coupling factors (20 through 50 dB). When operating over frequency bands greater than an octave, the flatness tolerance may need to be relaxed due to the inherent characteristics of coupling roll-off.

Another important consideration when specifying a coupler is to ensure the device has minimal mainline insertion loss. Through virtue of their design, coaxial air-line couplers offer the lowest possible loss when inserted in a transmission path. Generally, the **insertion loss** of a coupler (or any microwave device for that matter) becomes more significant at higher frequency, namely because loss increases with frequency and higher frequency power sources are considerably more expensive. Accordingly, the criteria of low insertion loss will prevent precious power from being wasted on measurement components.

Directional Coupler Basics (cont.)

When specifying a directional coupler with a coupling factor stronger than 20 dB (3, 6 or 10 dB), consideration should also be given to the theoretical insertion loss caused by power coupling from the mainline. **Table 1** illustrates the amount of additional loss the device exhibits as a function of the proximity of the two transmission lines. It should also be noted that dual directional couplers exhibit twice the loss of single directional models because there are two secondary lines drawing power from the mainline.

Table 1

Theoretical Mainline Insertion Loss Due to Coupling Factor (dB)							
Coupling Factor	3 dB	6 dB	10 dB	20 dB	30 dB	40 dB	50 dB
Single Directional Coupler	3.01	1.2560	0.4560	0.0436	0.0043	0.0004	0.00004
Dual Directional Coupler	6.02	2.5120	0.9120	0.0872	0.0086	0.0008	0.00008

Directional Coupler Solutions from DRAWCOM

We supply both coaxial air-line and stripline couplers. Through virtue of their design, air-line couplers are high power capable and offer the lowest possible insertion loss. The unique matching techniques used in their construction also provide exceptionally high directivity and the best possible VSWR. Stripline couplers offer the advantage of multi-octave frequency coverage in miniature package sizes for improved packaging density.

We supply a wide selection of directional couplers optimized to the microwave engineer's critical specifications. Standard coupling values of 3, 6, 10, 20, 30, 40 and 50 dB are available for just-in-time requirements. Custom options include dual and tri-couplers, special coupling values, frequency ranges to 18 GHz, external high power terminations and alternate connector styles or plating. All models may be specified without an internal termination for bi-directional coupling, and passive intermodulation (PIM) compliant models are available when silver-plated connectors are specified.

Source: www.e-meca.com