

## Waveguide Circulators & Isolators

DrawCom's Waveguide Circulators and Isolators are specifically designed to meet the requirements of high capacity and high performance microwave systems. The product line covers the frequency range from 2.7 GHz to 40 GHz.

Stringent performance parameters imposed during design and production phase of these devices, make them ideally suited for applications in communication, radar and terrestrial radio applications. Special attention is given to critical operating parameters such as isolation, return loss, insertion loss and intermodulation products.

Applications include channel combination and separation, antenna multiplexing, cross-channel and load isolation.

For waveguide isolators, electrical and mechanical characteristics are dependent on the specifications of the load used. The choice for the port to terminated is selectable.

Other options such as operating bandwidth, isolation, operating temperature range and type of flanges are available on require. Out in-house design and production capabilities, allow us to quote on almost any requirement.



# Waveguide Circulators & Isolators (cont.)

## Waveguide Circulators

Part No.	Frequency (GHz)	Waveguide Type	Minimum Isolation (dB)	Maximum Insertion Loss (dB)	Max VSWR	Maximum Forward Power (W - cw)	Style	Flange Type
M0977-1	3.50 - 4.20	WR229	26	0.20	1.10	400	MWC1	CMR
M0977-2	3.50 - 4.20	WR229	26	0.20	1.10	400	MWC1	CPR
M1399	3.50 - 4.20	WR229	26	0.20	1.10	400	MWC1	CPR
M2597	4.40 - 5.00	WR187	30	0.10	1.065	350	MWC2	CMR
M0952-1	5.85 - 6.45	WR137	26	0.20	1.10	300	MWC1	CPR
M0952-2	5.85 - 6.45	WR137	26	0.20	1.10	300	MWC1	CMR
M1400-1	5.85 - 6.45	WR137	30	0.10	1.065	2000	MWC3	Note 1
M1400-2	5.8 - 7.125	WR137	26	0.15	1.12	2000	MWC3	Note 1
M1100-1	6.40 - 7.20	WR137	26	0.25	1.10	300	MWC1	CPR
M1100-2	6.40 - 7.20	WR137	26	0.25	1.10	300	MWC1	CMR
M0975	7.10 - 8.50	WR112	26	0.15	1.10	300	MWC3	COVER
M1138	7.90 - 8.40	WR112	30	0.15	1.065	1800	MWC3	Note 2
M0957	9.30 - 9.80	WR90	25	0.20	1.12	100	MWC3	COVER
M2434-2	10.70 - 11.70	WR90	28	0.15	1.08	100	MWC1	Note 1
M2381	10.70 - 11.70	WR90	30	0.15	1.065	200	MWC3	Note 2
M1466	10.70 - 11.70	WR75	23	0.20	1.15	100	MWC3	COVER
M1898	11.00 - 12.70	WR75	21	0.15	1.20	500	MWC3	COVER
M1067-1	11.70 - 12.20	WR75	28	0.20	1.08	100	MWC3	COVER
M1067-2	12.50 - 12.75	WR75	28	0.20	1.08	100	MWC3	COVER
M1506	12.00 - 12.70	WR75	23	0.20	1.15	400	MWC3	COVER
M2062	14.00 - 14.50	WR75	26	0.10	1.10	900	MWC3	COVER
M1167	14.40 - 15.35	WR62	26	0.30	1.10	200	MWC3	COVER
M2594	18.60 - 19.90	WR42	20	0.30	1.22	20	MWC3	COVER
M2595	17.50 - 19.50	WR42	18	0.35	1.23	20	MWC3	COVER
M2596	19.00 - 20.60	WR42	18	0.35	1.26	20	MWC3	COVER
M2298	27.00 - 30.50	WR28	20	0.25	1.22	110	MWC3	Note 2
M2021	33.00 - 37.00	WR28	17	0.40	1.30	10	MWC3	Note 2

**Note 1:** Flange per customer require, (see Flange Numeric Codes on page 30) some restrictions may apply.

**Note 2:** Cover tapped

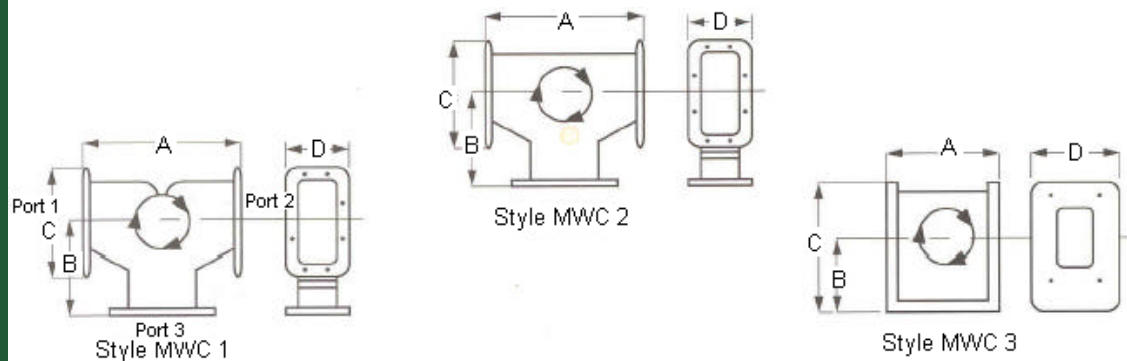

All information contained in the present data sheet is subject to confirmation at time of ordering. Print Date: 29/05/2009

# Waveguide Circulators & Isolators (cont.)

## Waveguide Isolators

Part No.	Frequency (GHz)	Waveguide Type	Minimum Isolation (dB)	Maximum Insertion Loss (dB)	Max VSWR	Maximum Forward Power (W - cw)	Maximum Reverse Power (W - cw)	Circulator Model (Cross Reference)
M1093	3.50 - 4.20	WR229	26	0.15	1.10	400	10	M0977
M0980	5.90 - 6.45	WR137	26	0.20	1.10	300	5	M0952
M1391-1	6.45 - 6.45	WR137	30	0.10	1.065	2000	150	M1400-1
M2056	5.85 - 6.45	WR137	26	0.20	1.12	300	10	M0952
M1391-2	5.80 - 7.125	WR137	25	0.15	1.12	2000	150	M1400-2
M1077	6.40 - 7.20	WR137	26	0.20	1.10	300	5	M1100
M1285	7.70 - 8.30	WR112	26	0.15	1.10	300	10	M0975
M1174	7.90 - 8.40	WR112	23	0.15	1.15	1800	75	M1138
M2115	9.20 - 10.20	WR90	23	0.20	1.15	100	75	M0957
M1287	10.70 - 11.70	WR90	28	0.15	1.08	100	2	M2434-2
M1467	10.70 - 11.70	WR75	23	0.20	1.15	100	5	M1466
M2074	11.00 - 13.00	WR75	23	0.20	1.15	100	10	M1466
M0992	11.70 - 12.20	WR75	28	0.20	1.10	100	5	M1067-1
M1857	11.70 - 12.20	WR75	26	0.15	1.10	100	75	M1067-1
M1743	14.00 - 14.50	WR75	26	0.15	1.10	900	15	M2062
M2173	18.60 - 19.90	WR42	20	0.30	1.22	20	2	M2594
M2359	17.50 - 19.50	WR42	18	0.35	1.28	20	2	M2595
M2360	19.00 - 20.60	WR42	18	0.35	1.28	20	2	M2596
M2149	27.00 - 30.00	WR28	20	0.25	1.22	100	1	M2298
M2163	28.50 - 30.50	WR28	20	0.25	1.22	100	1	M2298
M2373	34.00 - 36.00	WR28	23	0.40	1.15	10	1	M2021



# Waveguide Circulators & Isolators (cont.)

## ORDERING INFORMATION

### Circulators

1. select model from table.
2. Specify direction of circulation, for clockwise circulation (standard), add C. for counter-clockwise circulation, add **A** following base model number.
3. Select flange if applicable (see Flange Numeric Codes on page 30).
4. Add suffix **P** if pressurization is required (3 psig is standard).

### ORDERING EXAMPLE

Part No.	Circulation	Flange	Pressure
M1400-1	A	1	P

#### Part Number - M1400-1-A1--P

The example describes a WR137 circulator (5.85 - 6.45 GHz with counter-clockwise circulation and CPR-G flanges with pressurization)

### FLANGE NUMERIC CODES

Code	Flange*
1	CPR-G
2	CPR-F
3	CMR Standard
4	CMR 8 Clear Holes
5	CMR 8 Tapped Holes
6	UG Cover
7	UG Choke
8	Special: specify
9	PDR
10	UDR

*\*Brass unless otherwise requested*

### Isolators

1. select model from table.
2. Specify direction of circulation, for clockwise circulation (standard), add C. for counter-clockwise circulation, add **A** following base model number.
3. Specify termination port.
4. Select flange if applicable (see Flange Numeric Codes on page 30).
5. Add suffix **P** if pressurization is required (3 psig is standard).

### ORDERING EXAMPLE

Part No.	Circulation	Termination	Flange	Pressure
M2115	C	3	5	-

#### Part Number - M2115-C-3-5

The example describes a WR90 Isolator with clockwise circulation terminated on Port 3 with CMR tapped flanges

### ORDERING EXAMPLE

Part No.	Circulation	Termination	Flange	Pressure
M1391-1	A	1	5	-

#### Part Number - M1391-1-A-1-5

The example describes a WR137 Isolator (5.85 - 6.425) with counter-clockwise circulation, terminated on Port 1 with CMR tapped flanges.

If the above tables and ordering information do not fulfil your needs, please let us quote against your specification.