

Variable Power Combiner



DrawCom's Variable Power Combiners are used in Satellite Earth Stations & operate in the C, X, K & Ku-Bands. Within the Ku-Band, models for both lower and upper communications frequency ranges are available.

The Variable Power Combiners are primarily used to:

1. Switch a transmitter to one of two output ports for redundancy, or to divide the transmitter between two ports.
2. Combine two transmitters to either one of two ports and to provide variable output combinations.

Electrical Spec.	Ku-Band	C-Band	X-Band
Frequency Range	14.0 – 14.5 GHz	5.850 – 6.425 GHz	7.9 – 8.4 GHz
VSWR (at any port)	1.15:1 max	1.15:1 max	1.15:1 max
Insertion Loss	0.2 dB max	0.2 dB max	0.2 dB max
Isolation (minimum)			
A-B (all position)	30 dB	30 dB	30 dB
A-D (A to C position)	40 dB	40 dB	40 dB
B-D (B to C position)	40 dB	40 dB	40 dB
C-D (all positions)	30 dB	30 dB	30 dB
Power Handling	2kW (1kW per port)	6kW (1kW per port)	3kW (1kW per port)
(1) Pressure	15 PSIG	15 PSIG	15 PSIG
Operating Voltage	18 – 28 V DC	18 – 28 V DC	18 – 28 V DC
Dry Contact Closure	SPDT	SPDT	SPDT
Control Contact (dry)	Momentary SPDT	Momentary SPDT	Momentary SPDT
Control Voltage	24/28 V DC	28 V DC	28 V DC
Switching Time	Typical 25 ms between adjacent steps (at 24V)	Typical 100 ms between adjacent steps (at 24V)	Typical 30 ms between adjacent steps (at 24V)
Power Spilt	3 dB ± 0.1 dB	3 dB ± 0.1 dB	3 dB ± 0.1 dB
Manual Override	Included	Included	Included

(1) Leakage Rate of 15cc / minute typical

Part No.

M1655	C-Band, Electrically operated with manual override
M1644	x-Band, Electrically operated with manual override
M2706	Ku-Band, Electrically operated with manual override
M1707	K-Band, Electrically operated with manual override

Note: Each of the above units has a "manually operated" model.

Variable Power Combiner (cont.)

Connectors for K, KU & X-Bands Models				
P "1" Pin Configuration 25 Pin D-Sub-miniature, Male			P "2" Pin Configuration 9 Pin D-Sub-miniature, Male	
1	VPC Position 0°	Ind. Output	1	24 VDC
2	VPC Position 22.5°	Ind. Output	2	24 VDC
3	VPC Position 45°	Ind. Output	3	24 VDC
4	VPC Position 67.5°	Ind. Output	4	24 VDC
5	VPC Ind. Output Common		5	Chassis Ground
6	Manual Reset Input		6	24 VDC Ground
7	Not Used		7	24 VDC Ground
8	Not Used		8	24 VDC Ground
9	Not Used		9	24 VDC Ground
10	Tx A			
11	Tx B			
12	Not Used			
13	Not Used			
14	VPC Position 0°	Com. Input		
15	VPC Position 22.5°	Com. Input		
16	VPC Position 45°	Com. Input		
17	VPC Position 67.5°	Com. Input		
18	VPC Position Command Input Common			
19	Manual Reset Input Common			
20	Not Used			
21	Not Used			
22	Not Used			
23	Rx A			
24	Rx B			
25	Signal Ground			

Connectors for C-Bands Models				
P "1" Pin Configuration 15 Pin D-Sub-miniature, Male			P "2" Pin Configuration 4 Pin D-Sub-miniature, Male	
1	A to D & B to C		1	24 VDC @ 10A
2	A + B to D		2	GND
3	A to C & B to D		3	GND
4	A + D to C		4	N/C
5	Reset Input			
6	N/C			
7	GND			
8	GND			
9	A to D & B to C			
10	A + B to D			
11	A to C & B to D			
12	A + B to C			
13	HPA A Fault Input (opt)			
14	HPA B Fault Input (opt)			
15	Auto Command Input (opt)			

Variable Power Combiner (cont.)

Dim.*	K & Ku-Band	X-Band	C-Band
A	10.15	13.87	19.00
B	7.88	11.50	15.90
C	4.90	5.43	7.76
D	4.60	4.98	6.12
E	3.70	3.70	5.95
F	5.05	6.00	8.00

*Dimensions in inches

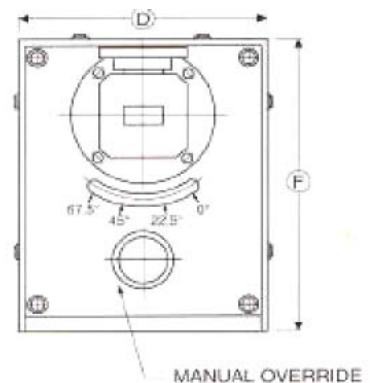
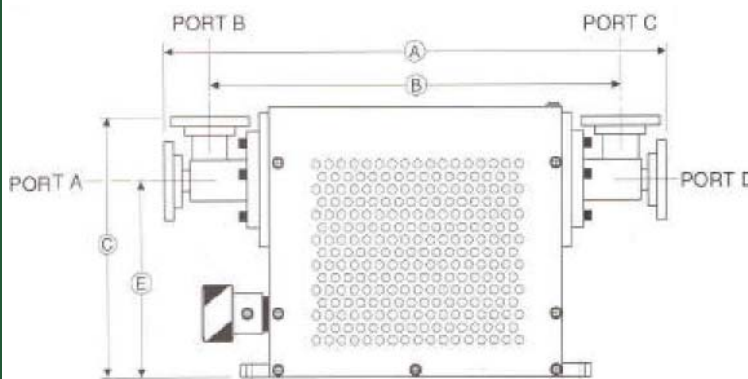
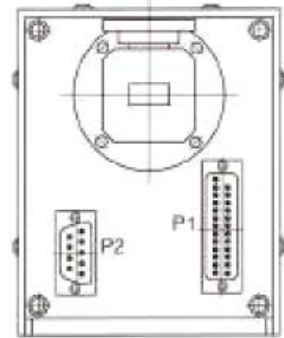

Polarizer Position	Angle (°)	Applied Power	Power Observed at Port C Less I. L. (0.2)dB	Power Observed at Port D Less I. L. (0.2)dB
A to D	0°	A & B	Full Power of B	Full Power of A
A + B to D	22.5°	A only	Half Power of A	Half Power of A
		B only	Half Power of B	Half Power of B
		A & B not phase adjusted	Partial Power of A & B	Partial Power of A & B
		A & B phase adjusted*	Negligible Power	Full Combined Power of A & B
B to D	45°	A & B	Full Power of A	Full Power of B
A + B to C	67.5°	A only	Half Power of B	Half Power of A
		B only	Half Power of A	Half Power of B
		A & B not phase adjusted	Partial Power of A & B	Partial Power of A & B
		A & B phase adjusted*	Full Combined Power of A & B	Negligible Power

* A & B must have equal carrier magnitude & frequency